

**1W&3W High Power 3535 White LED
Technical Data Sheet**

Part No.: DL-PCB3535W

Double Light

◆ Features:

1. Small package with high efficiency
2. Long operating life.
3. Available in white, green, blue, red, yellow, Amber
4. Typical color temperature: 5500-6500 K.
5. View angle: 120°.
6. Low voltage DC operated.
7. The product itself will remain within RoHS compliant Version.
8. ESD protection.

◆ Applications:

1. Reading lights (car, bus, aircraft).
2. Portable (flashlight, bicycle).
3. Mini accent/Uplighters/Downlighters/Orientation.
4. Bollards/Security/Garden.
5. Cove/Undershelf/Task.
6. Automotive rear combination lamps.
7. Traffic signaling/Beacons/ Rail crossing and Wayside.
8. Indoor/Outdoor Commercial and Residential Architectural.
9. Edge lit signs (Exit, point of sale).
10. LCD Backlights/Light Guides.

Double Light

◆ Mechanical Dimensions

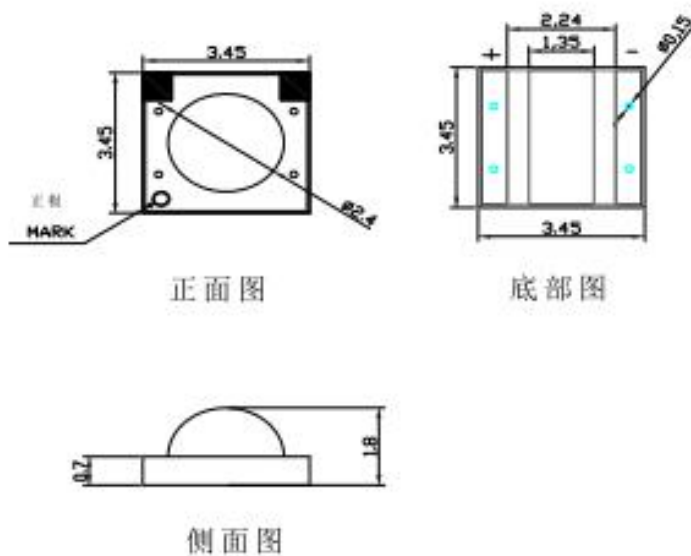

Part No.	Chip Material	Lens Color	Source Color
DL-PCB3535W	InGaN	Yellow Diffused	White

Notes:

1. All dimensions are in millimeters.
2. Tolerance is ± 0.25 mm (.010") unless otherwise noted.
3. Specifications are subject to change without notice.

Double Light

◆ Absolute Maximum Ratings at Ta=25°C

Parameters	Symbol	Max.	Unit
Power Dissipation	PD	3000	mW
Peak Forward Current (1/10 Duty Cycle, 0.1ms Pulse Width)	IFP	1000	mA
Forward Current	IF	350/700	mA
Reverse Voltage	VR	5	V
Electrostatic Discharge (HBM)	ESD	1000	V
Operating Temperature Range	Topr	-10°C to +70°C	
Storage Temperature Range	Tstg	-20°C to +80°C	
Soldering Temperature	Tsld	260°C for 5 Seconds	

Electrical Optical Characteristics at Ta=25°C

Parameter	Symbol	Min.	Typ.	Max.	Unit	Test Condition
Luminous Flux	Φ	100	120	130	lm	If=350mA (Note 1)
		200	220	240	lm	If=700mA (Note 1)
Viewing Angle	2θ(1/2)	---	90	---	Deg	(Note 2)
Color Temperature	TC	5500	---	6500	K	If=350/700mA
Forward Voltage	VF	2.80	3.40	3.80	V	If=350/700mA
Reverse Current	IR	---	---	10	μA	VR=5V

Notes:

1. $\theta_{1/2}$ is the off-axis angle at which the luminous intensity is half the axial luminous intensity.

Double Light

◆ CIE Chromaticity Diagram:

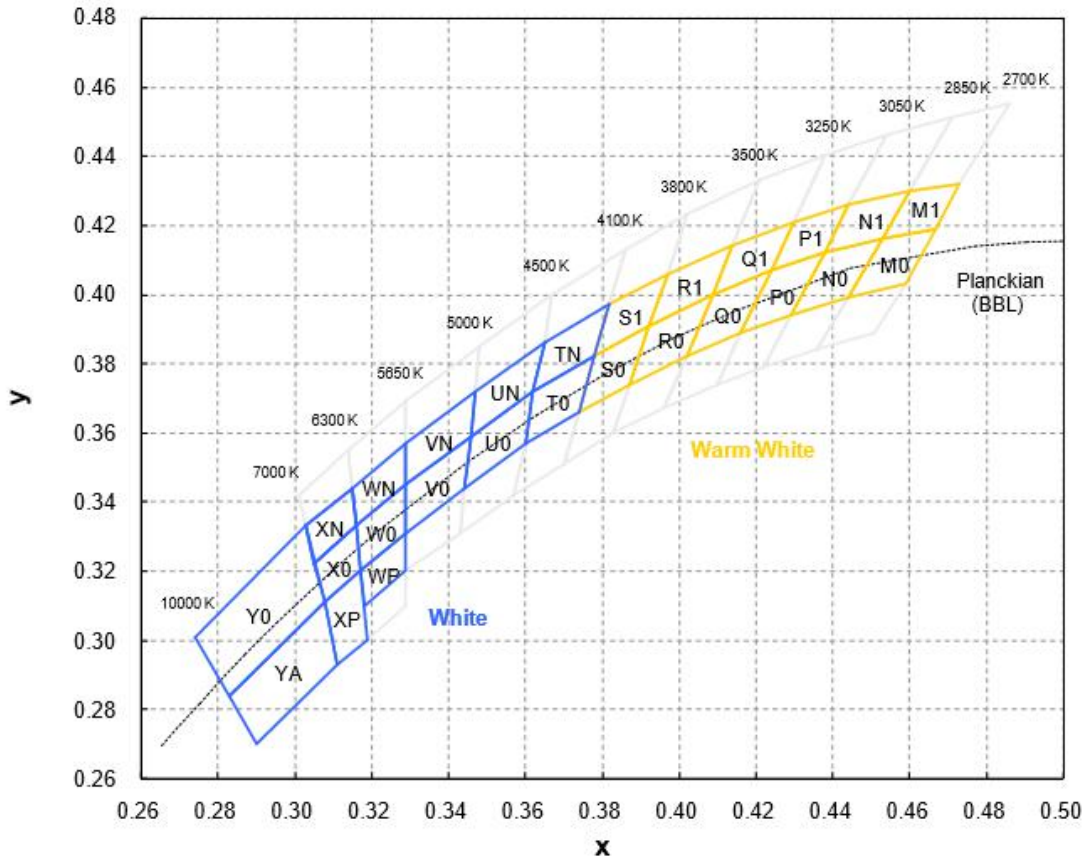

◆ Color Bin Limits

Bin Code	x	y	Typ. CCT (K)	Bin Code	x	y	Typ. CCT (K)
T0	0.378	0.382	4300	WN	0.329	0.345	5970
	0.374	0.366			0.316	0.333	
	0.360	0.357			0.315	0.344	
	0.362	0.372			0.329	0.357	
TN	0.382	0.397	4300	WP	0.329	0.331	5970
	0.378	0.382			0.329	0.320	
	0.362	0.372			0.317	0.320	
	0.365	0.386			0.308	0.311	
U0	0.360	0.357	4750	X0	0.305	0.322	6650
	0.344	0.344			0.316	0.333	
	0.346	0.359			0.317	0.320	
	0.365	0.386			0.305	0.322	
UN	0.362	0.372	4750	XN	0.303	0.333	6650
	0.346	0.359			0.315	0.344	
	0.347	0.372			0.316	0.333	
	0.329	0.331			0.308	0.311	
V0	0.329	0.345	5320	XP	0.317	0.320	6650
	0.346	0.359			0.319	0.300	
	0.344	0.344			0.311	0.293	
	0.329	0.345			0.308	0.311	
VN	0.329	0.357	5320	Y0	0.283	0.284	8000
	0.347	0.372			0.274	0.301	
	0.346	0.359			0.303	0.333	
	0.329	0.345			0.308	0.311	
W0	0.329	0.331	5970	YA	0.311	0.293	8000
	0.317	0.320			0.290	0.270	
	0.316	0.333			0.283	0.284	

Double Light

◆ Typical Electrical / Optical Characteristics Curves

(25°C Ambient Temperature Unless Otherwise Noted)

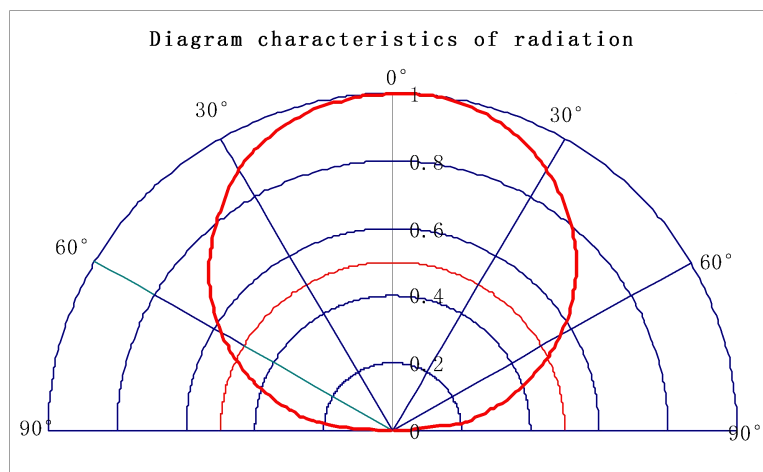
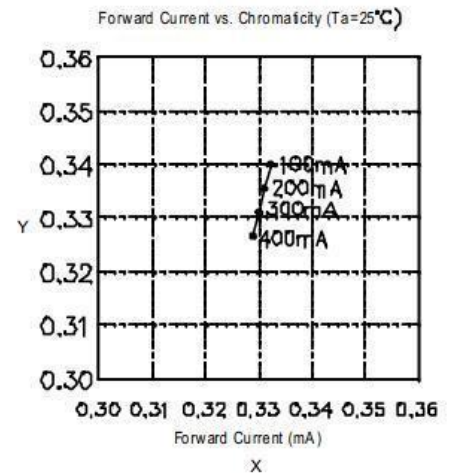
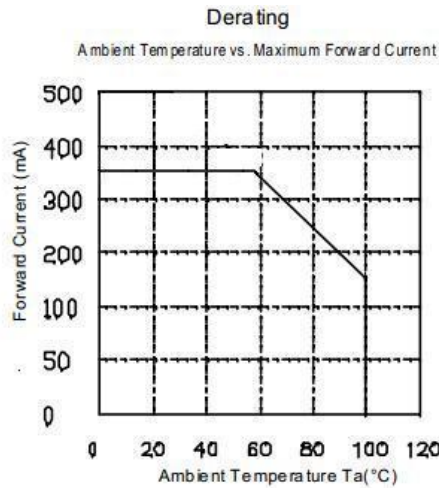
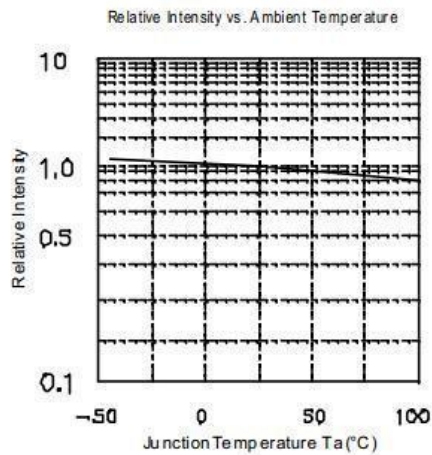
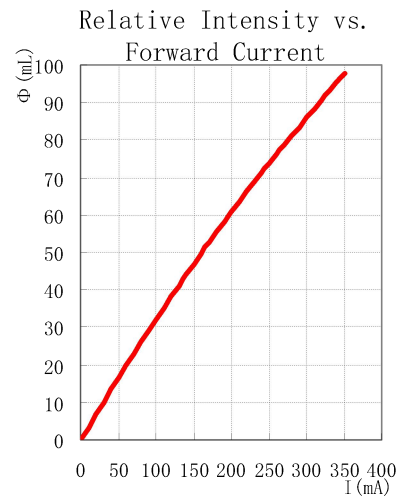
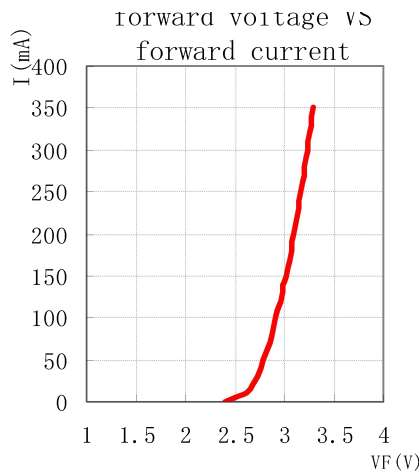
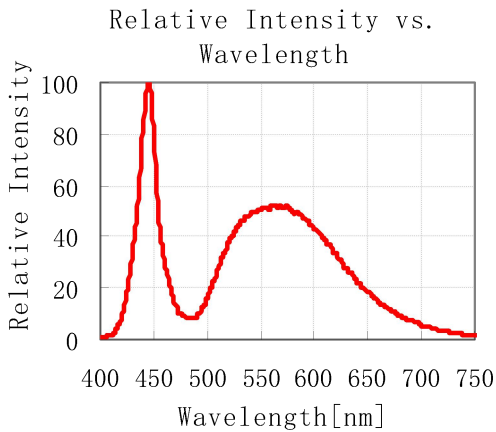

Double Light

◆ Reliability Test Items And Conditions:

The reliability of products shall be satisfied with items listed below:

Confidence level: 90%.

LTPD: 10%.

No.	Item	Test Conditions	Test Hours/ Cycles	Sample Sizes	Failure Judgment Criteria	Ac/ Re
1	Reflow Soldering	TEMP.: 260°C±5°C 5secs	6mins	22pcs	$IR \geq U*2$ $Ee \leq L*0.8$ $VF \geq U*1.2$ U: Upper Specification Limit L: Lower Specification Limit	0/1
2	Temperature Cycle	H: +100°C 15mins ┆ 5 mins ┆ L: -40°C 15mins	50Cycles	22pcs		0/1
3	Thermal Shock	H: +100°C 15mins ┆ 10mins ┆ L: -10°C 5mins	50Cycles	22pcs		0/1
4	High Temperature Storage	TEMP.: +100°C	1000hrs	22pcs		0/1
5	Lower Temperature Storage	TEMP.: -40°C	1000hrs	22pcs		0/1
6	DC Operating Life	V _{CE} =5V	1000hrs	22pcs		0/1
7	High Temperature/ High Humidity	85°C / 85% R.H.	1000hrs	22pcs		0/1

Double Light

◆ Reel Dimensions:

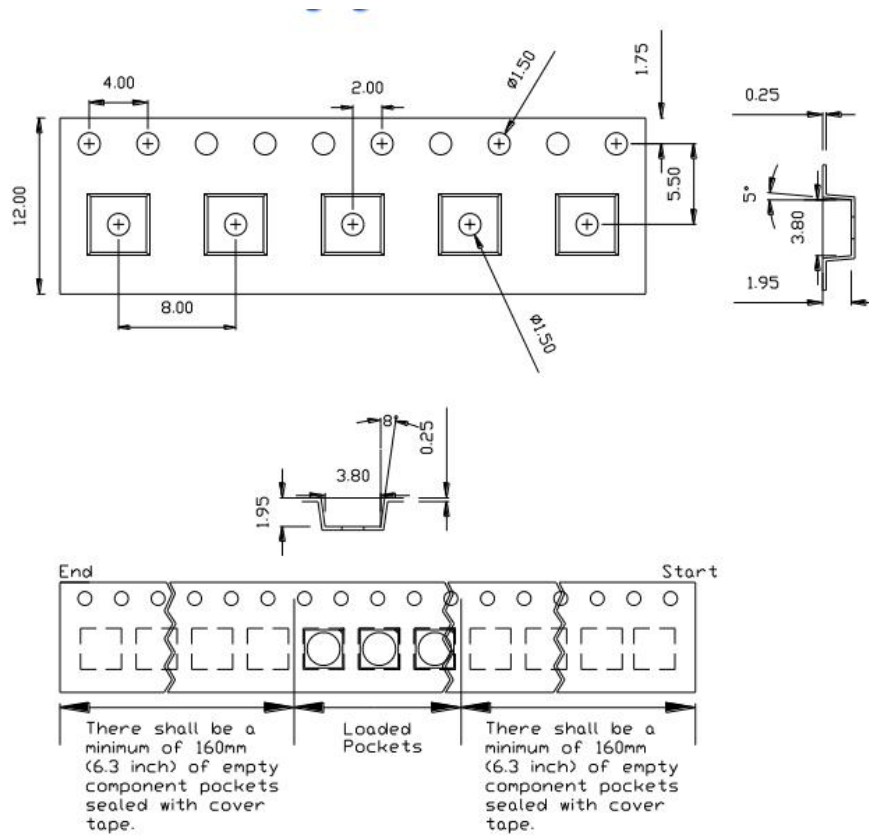

Loaded quantity 1000 per reel.

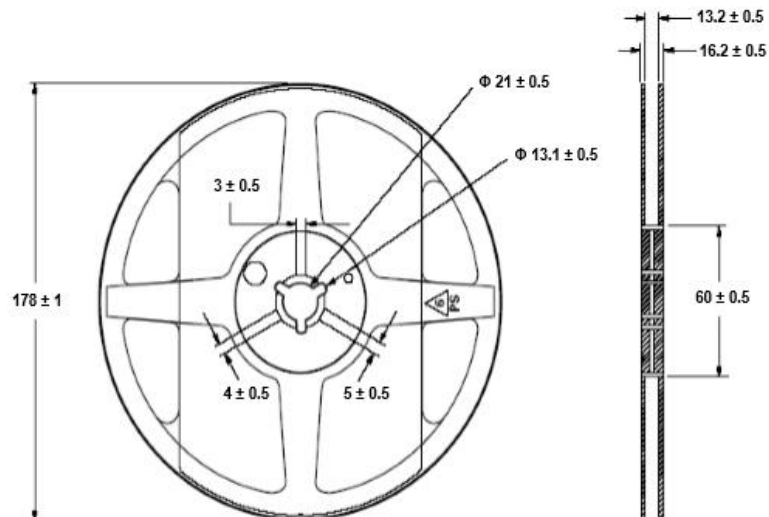
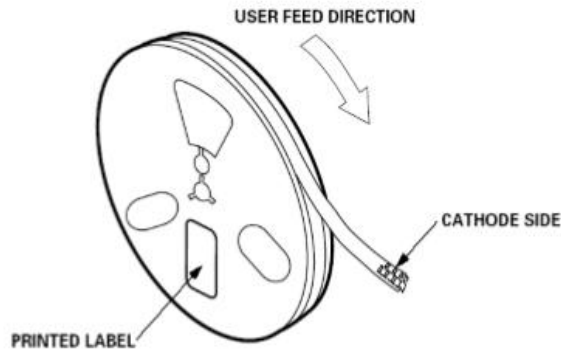

Double Light

◆ Precautions for Use:

1. Over-current-proof

Customer must apply resistors for protection, otherwise slight voltage shift may cause enormous current change and burn out failure would happen.

2. Storage

- a) Do not open moisture proof bag before the products are ready to use.
- b) Before opening the package, the Infrareds should be kept at 30°C or less and 90%RH or less.
- c) The Infrared LED should be used within a year.
- d) After opening the package, the Infrareds should be kept at 30°C or less and 70%RH or less.
- e) The Infrared LED should be used within 168 hours (7 days) after opening the package.
- f) If the moisture absorbent material (silicone gel) has faded away or the Infrareds have exceeded the storage time, baking treatment should be performed using the following conditions.
- g) Pre-curing treatment: 60±5°C for 24 hours.

3. Thermal Management

- a) Because the Infrared LED is a high power dissipation device, special and sufficient consideration in thermal management design must be made to optimize the thermal performance.
- b) Heat sink design is implemented in the device for an additional thermal connection. Since the device is capable of SMT process, tin must be spread both heat sink and solder pads areas to dissipate the heat.
- c) A high thermal conductivity substrate, such as Aluminum or Copper plate etc, must be applied for external thermal management. It is strongly recommended that the outer heat sink or PCB dimension per Infrared LED can not be less than 25 x 25 x 1 (L x W x H) mm. The materials for outer heat sink can be FR4 on Aluminum, MCPCB, or FPC on Aluminum.
- d) Special thermal designs are also recommended to take in outer heat sink design, such as FR4 PCB on Aluminum with thermal vias or FPC on Aluminum with thermal conductive adhesive, etc.
- e) Sufficient thermal management must be conducted, or the die junction temperature will be over the limit under large electronic driving and Infrared LED lifetime will decrease critically.

4. Soldering Condition

- a) Reflow soldering should not be done more than two times.
- b) While soldering, do not put stress on the Infrareds during heating.
- c) After soldering, do not warp the circuit board.

5. Soldering Iron

- a) For prototype builds or small series production runs it is possible to place and solder the LED by hand.
- b) Dispensing thermal conductive glue or grease on the substrates and follow its curing spec. Press Infrared housing to closely connect Infrared and substrate.
- c) It is recommended to hand solder the leads with a solder tip temperature of 280°C for less than 3 seconds within once in less than the soldering iron capacity 25W. Leave two seconds and more intervals, and do soldering of each terminal.
- d) Be careful because the damage of the product is often started at the time of the hand solder.

6. Handling Indications

- a) During processing, mechanical stress on the surface should be minimized as much as possible.